

NOTES FOR MOUNTING ASSEMBLY

- 1 LOWER MOUNTING ASSEMBLY, WITH GASKET.
- 2 UPPER MOUNTING ASSEMBLY (TAB).
- 3 BOLT, 1/2", STAINLESS STEEL, WITH SELF-LOCKING NUT.
- 4 FLAT WASHER, STAINLESS STEEL.
- 5 BUSHING, BRONZE.
- 6 MOUNTING BOLT, 1/4" MINIMUM, WITH NUT AND LOCKWASHER, OR SELF-LOCKING NUT AND COTTER KEY.

NOTE:
FOR INTERNALLY ILLUMINATED STREET NAME SIGN, MOUNTING HARDWARE, AND ELECTRICAL DETAILS SEE CITY STD MVL-411B-0 STATE STANDARD ES-70 AND THE SPECIAL PROVISIONS.

HORIZONTAL MAST ARM

INSTALL IISNS ON HORIZONTAL MAST ARM 8 FEET ABOVE TOP OF SMA SIMPLEX TO CENTER OF IISNS ARM SIMPLEX. THE MANUFACTURER SHALL PROVIDE CERTIFICATION TO THE CITY THAT THE POLE IS DESIGNED TO ACCOMMODATE THE ADDITIONAL MAST ARM, MOUNTINGS AND INTERNALLY ILLUMINATED STREET NAME SIGN.

NOTES FOR HORIZONTAL MAST ARM

ROUND TAPERED STEEL TUBE 0.1793" WITH MAXIMUM TAPER OF 0.14 INCHES PER FOOT AND 5 1/2" OD MAXIMUM AT POLE, ASTM A-36 & 53. IN LIEU OF THE TORQUE REQUIREMENTS FOR HS BOLTS, CAP SCREWS SHALL BE TIGHTENED BY THE TURN-OF-NUT METHOD, 1/3 TURN FROM SNUG TIGHT CONDITION. NO WASHER WILL BE REQUIRED. CALTRANS STANDARD DRAWING ES-6S, DETAIL 'F', FATIGUE RESISTANT WELD, IS REQUIRED AT IISNS ARM PLATE AND POLE BASE PLATE.

SPECIFICATIONS

DESIGN: AASHTO SPECIFICATIONS FOR THE DESIGN AND CONSTRUCTION OF STRUCTURAL SUPPORTS FOR HIGHWAY SIGNS, LUMINAIRES AND TRAFFIC SIGNALS, DATED 2004 (4TH EDITION).

WIND LOADINGS: 100 MPH AASHTO

UNIT STRESSES

STRUCTURAL STEEL : $f_y = 331 \text{ MPa}$ (TAPERED SHEET STEEL)
 $f_y = 248 \text{ MPa}$ UNLESS NOTED OTHERWISE

CONSTRUCTION: STANDARD SPECIFICATIONS AND THE SPECIAL PROVISIONS.

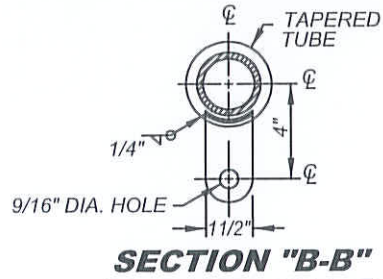
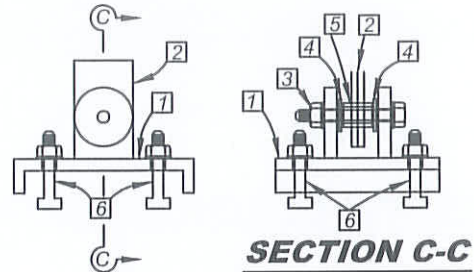

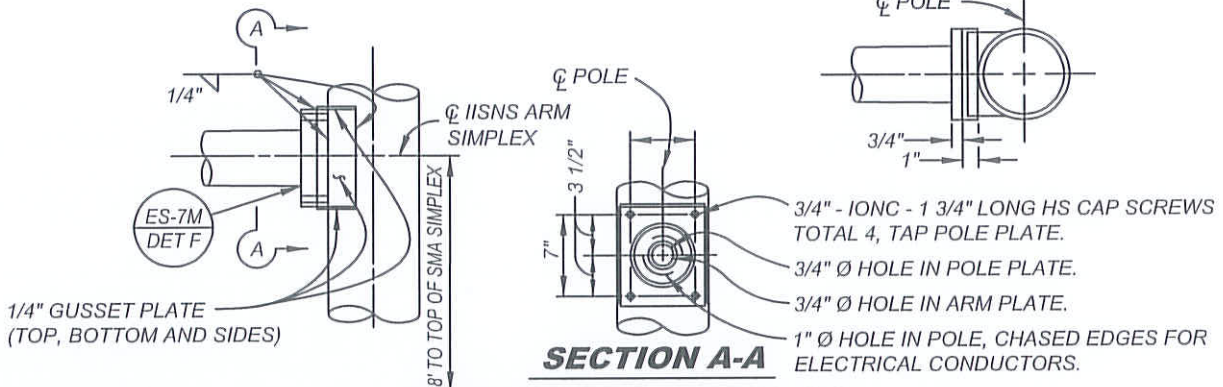

NOTES:

- 1. MATERIAL: STEEL OF 48,000 PSI MIN. YIELD AFTER FABRICATION.
- 2. HOT DIP GALVANIZED FINISH PER ASTM A-123.
- 3. ALL WELDS SHALL CONFORM TO AWS D1.1 SPECIFICATIONS.
- 3. BASE PLATES AND FLANGES SHALL BE PER ASTM A-35 & A-36 STEEL

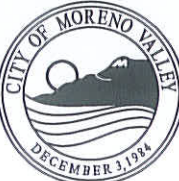

MOUNTING PLATE DETAIL

NOT TO SCALE

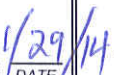
	RECOMMENDED: <div style="display: flex; justify-content: space-between;"> <div style="text-align: center;">  DIVISION MANAGER </div> <div style="text-align: center;">  DATE </div> </div>	<h2 style="margin: 0;">CITY OF MORENO VALLEY</h2> <p style="margin: 0;">PUBLIC WORKS DEPARTMENT - TRANSPORTATION ENGINEERING DIVISION</p>	STANDARD PLAN
	APPROVED: <div style="display: flex; justify-content: space-between;"> <div style="text-align: center;">  PUBLIC WORKS DIRECTOR / CITY ENGINEER </div> <div style="text-align: center;">  DATE </div> </div>	<h3 style="margin: 0;">MOUNTING ASSEMBLY - ILLUMINATED STREET NAME SIGN SPECIFICATIONS</h3>	<h2 style="margin: 0;">MVL-411D-0</h2>